

MINOLTA www.minolta.com

The essentials of imaging

www.minolta.com

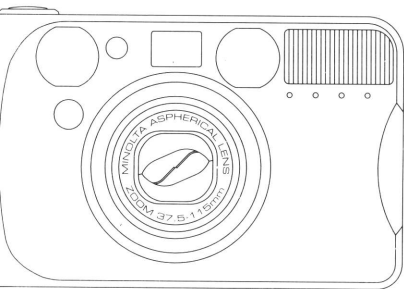

FREEDOM ZOOM 115

RIVA ZOOM 115

E INSTRUCTION MANUAL

CONTENTS

Contents	2
For Proper and Safe Use	3











GETTING STARTED

Name of Parts	10
Inserting the Battery	14
Battery Condition Indicator	16
Loading the Film	17
Rewinding the Film	20

BASIC OPERATION

Full-auto Operation	25
Focus Lock	29
For Close Subjects	31
Special Focusing Situations	34

ADVANCED OPERATION

Selecting Functions in the Flash Mode	36
Flash Range	38
 AUTO Autoflash	39
 AUTO Autoflash with Red-eye Reduction	40
 Fill flash	42
 Flash cancel	43
 AUTO AA Auto-depth	44
  Night Portrait	46
  Landscape/Night View	47
 Self-timer	48
For Owners of the Quartz-date Model	50
Attaching the Camera Strap	56

APPENDIX

Care and Storage	58
Technical Specifications	62

Read and understand all warnings and cautions before using this product.

 **WARNING**

Using batteries improperly can cause them to leak harmful solutions, overheat, or explode which may damage property or cause personal injury. Do not ignore the following warnings.

- Only use the batteries specified in this instruction manual.
- Do not install the batteries with the polarity (+/−) reversed.
- Do not use batteries which show wear or damage.
- Do not expose batteries to fire, high temperatures, water, or moisture.
- Do not attempt to recharge, short, or disassemble batteries.
- Do not store batteries near or in metallic products.
- Do not use leaking batteries. If fluid from the batteries enters your eye, immediately rinse the eye with plenty of fresh water and contact a doctor. If fluid from the batteries makes contact with your skin or clothing, wash the area thoroughly with water.



This manual is for reference and historical purposes, all rights reserved.

This page is copyright© by M. Butkus, NJ.

This page may not be sold or distributed without the expressed permission of the producer
I have no connection with any camera company

On-line camera manual library

This is the full text and images from the manual. This may take 3 full minutes for the PDF file to download.

If you find this manual useful, how about a donation of \$3 to: M. Butkus, 29 Lake Ave., High Bridge, NJ 08829-1701 and send your e-mail address so I can thank you. Most other places would charge you \$7.50 for a electronic copy or \$18.00 for a hard to read Xerox copy.

This will allow me to continue to buy new manuals and pay their shipping costs.

It'll make you feel better, won't it?

**If you use Pay Pal or wish to use your credit card,
click on the secure site on my main page.**

PayPal Name Lynn@butkus.org

Venmo @mike-butkus-camera Ph. 2083

www.PayPal.me/lynnbutkus

FOR PROPER AND SAFE USE

- Tape over lithium battery contacts to avoid short-circuiting during disposal; always follow local regulations for battery disposal.
- Do not disassemble this product. Electric shock may cause injury if a high voltage circuit inside the product is touched. Take the product to a Minolta Service Facility when repairs are required.
- Immediately remove the batteries and discontinue use if the camera is dropped or subjected to an impact in which the interior, especially the flash unit, is exposed. The flash has a high voltage circuit which may cause an electric shock resulting in injury. The continued use of a damaged product or part may cause injuries.
- Keep batteries or small parts that could be swallowed away from infants. Contact a doctor immediately if an object is swallowed.
- Store this product out of reach of children. Be careful when around children, not to harm them with the product or parts.
- Do not fire the flash directly into the eyes. It may damage eyesight.

- Do not fire the flash at vehicle operators. It may cause a distraction or temporary blindness which may lead to an accident.
- Do not look directly at the sun or strong light sources through the viewfinder. It may damage your eyesight or cause blindness.
- Do not use the product near inflammable gases or liquids such as gasoline, benzine, or paint thinner. Do not use inflammable products such as alcohol, benzine, or paint thinner to clean the product. The use of inflammable cleaners and solvents may cause an explosion or fire.
- If the product emits a strange odor, heat, or smoke, discontinue use. Immediately remove the batteries taking care not to burn yourself. The continued use of a damaged product or part may cause injuries.
- Take the product to a Minolta Service Facility when repairs are required.

 **CAUTION**

- Do not use or store the product in a hot or humid environment such as the glove compartment or trunk of a car. It may damage the product and batteries which may result in burns or injuries caused by heat, fire, explosion, or leaking battery fluid.
- If batteries are leaking, discontinue use of the product.
- The lens retracts when the camera is turned off or the auto-power-off function is activated. Touching the lens barrel while it is retracting may cause injury.
- Do not fire the flash while it is in contact with people or objects. The flash unit discharges a large amount of energy which may cause burns.

This device complies with Part 15 of the FCC Rules. Operation is subject to the following two conditions: (1) This device may not cause harmful interference, and (2) this device must accept any interference received, including interference that may cause undesired operation. Changes or modifications not approved by the party responsible for compliance could void the user's authority to operate the equipment. This equipment has been tested and found to comply with the limits for a Class B digital device, pursuant to Part 15 of the FCC Rules. These limits are designed to provide reasonable protection against harmful interference in a residential installation. This equipment generates, uses and can radiate radio frequency energy and, if not installed and used in accordance with the instructions, may cause harmful interference to radio communications. However, there is no guarantee that interference will not occur in a particular installation.

FOR PROPER AND SAFE USE

If this equipment does cause harmful interference to radio or television reception, which can be determined by turning the equipment off and on, the user is encouraged to try to correct the interference by one or more of the following measures:

- Reorient or relocate the receiving antenna.
- Increase the separation between the equipment and the receiver.
- Connect the equipment to an outlet on a circuit different from that to which the receiver is connected.
- Consult the dealer or an experienced radio/TV technician for help.

This Class B digital apparatus complies with Canadian ICES-003.



This mark on your camera certifies that this camera meets the requirements of the EU (European Union) concerning interference causing equipment regulations. CE stands for Conformité Européenne (European Conformity).

GETTING STARTED

Thank you for purchasing this Minolta camera. Your new camera is with functions which will suit your every photographic need. Before using your new camera, please take the time to read through this instruction manual for important information on the use and care of your camera.

ICONS USED IN THIS MANUAL



important user notices



supplimentary user information

NAME OF PARTS

BODY

For information on specific parts, refer to the page numbers shown in parenthesis.

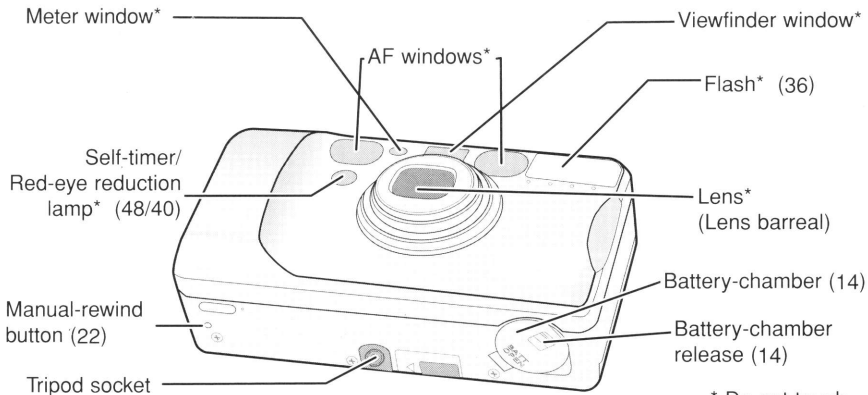

* Do not touch

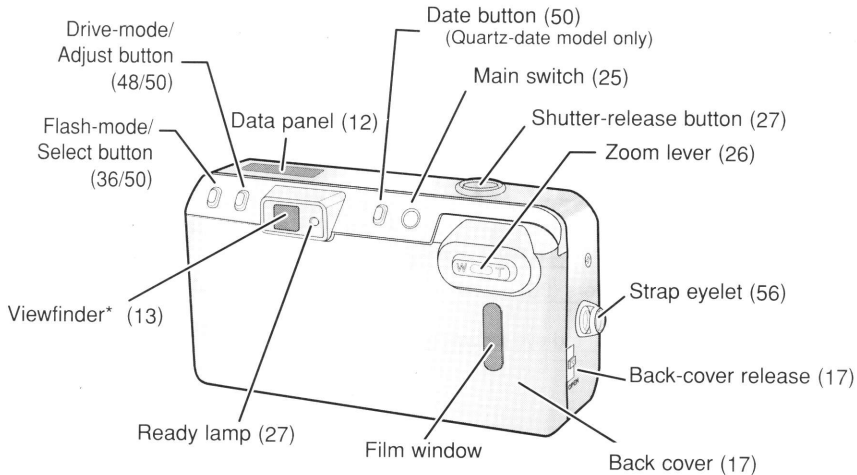





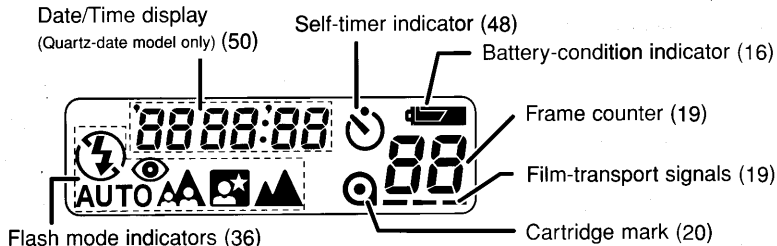

Continued on next page.

NAME OF PARTS

DATA PANEL Only the necessary indicators will appear on the data panel.



-  Autoflash
-  Autoflash with red-eye reduction
-  Fill flash
-  Flash cancel
-  Auto-depth
-  Night Portrait (with red-eye reduction)
-  Landscape/Night view

VIEWFINDER

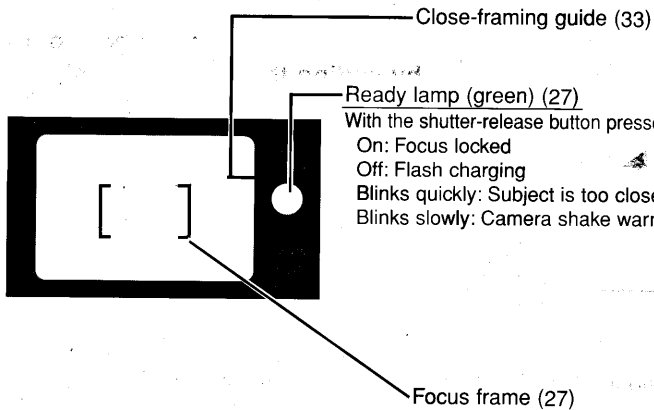

Ready lamp (green) (27)

With the shutter-release button pressed partway down -

On: Focus locked

Off: Flash charging

Blinks quickly: Subject is too close

Blinks slowly: Camera shake warning

Focus frame (27)

INSERTING THE BATTERY

Your camera uses one 3-volt CR123A or DL123A lithium battery.

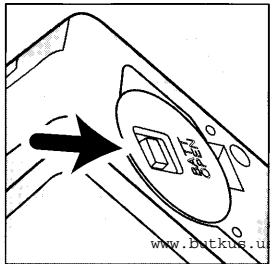
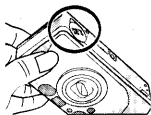

1. Open the battery-chamber door by sliding the battery-chamber release in the direction indicated.



- Quartz-date model: The date and time must be reset (p.50).
- When changing batteries, make sure the main switch is off.

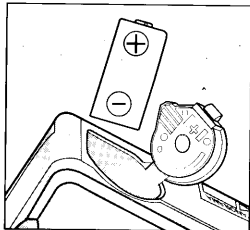

2. Insert the battery matching the positive terminal mark inside the battery chamber-door, then click the door closed.

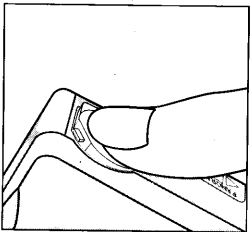

BATTERY CONDITION INDICATOR

Each time the camera is turned on, a symbol will appear on the data panel to indicate the power status of the battery.

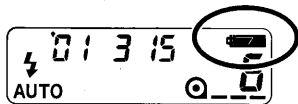

Briefly appears. Power is sufficient for all camera operations.

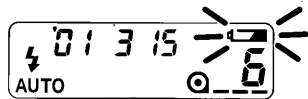

Power is sufficient, but the battery must be replaced soon.



Replace the battery. The shutter will lock until the battery is replaced.

LOADING THE FILM

www.butkus.us

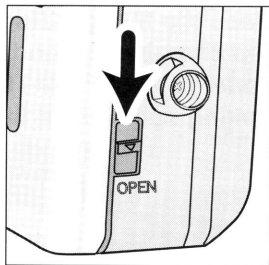
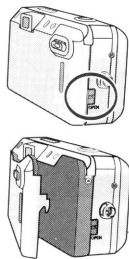

1. Slide the back-cover release down to open the back cover.



- If the back cover does not open, turn the main switch off and on to release the film chamber lock.
- Use only 35mm, DX-coded film rated between ISO 25 and 3200.
- Do not use Polaroid instant 35mm film. Winding problems may occur.
- ISO 400 film is recommended for best results.
- Always load and unload film in subdued light.

Continued on next page.

LOADING THE FILM

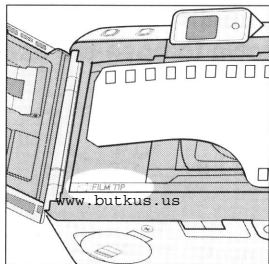
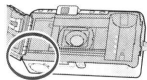

2. Place the film cartridge into the film chamber. Extend the film leader to the "FILM TIP" mark, making sure it lays flat.



- If the film tip extends beyond the index mark, push the excess film back into the cartridge.

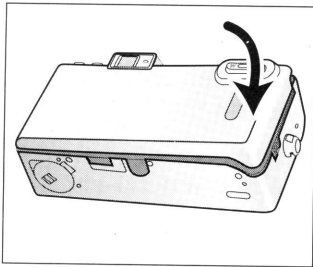

3. Close the back cover.

- The film automatically advances to the first frame and $\odot \dots i$ appears on the data panel.
- If the film has been loaded improperly, $\odot \square$ will blink on the data panel and the shutter will remain locked. Open the back cover and repeat the loading procedure.



- Once the film is loaded, the back cover will lock preventing accidental opening until the film is rewound (film chamber lock).

REWINDING THE FILM

Your camera automatically rewinds the film after the last exposure is taken.

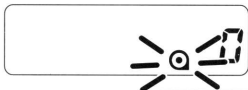

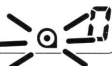
When  blinks on the data panel, open the back cover and remove the film.

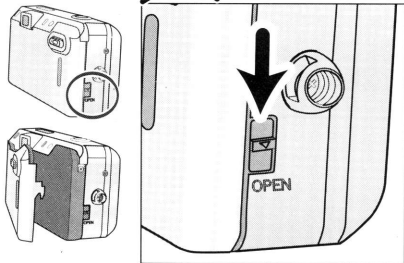

- When you want to rewind quietly (silent rewind), push the manual-rewind button while the film is rewinding (p.23).



- Do not open the back cover until the rewind motor stops. Never use force.



- If the rewind motor stops before the film has been completely rewound, all the indicators will blink. Remove and insert the battery or press the manual-rewind button.
- If the back cover does not open, turn the main switch off and on to release the film chamber lock.
- Although more pictures than specified on the roll may be taken, the film processor may not print more than the number specified on the film cassette.

REWINDING THE FILM

MANUAL REWIND

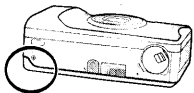

To rewind before the end of the roll, turn the camera on and gently press the manual rewind button using the button key on the strap.

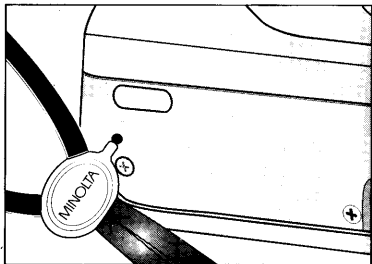

SILENT REWIND

This camera has a silent-rewind function to minimize the noise of film rewinding. Use the silent-rewind mode when the rewinding noise would be distracting such as during a wedding ceremony.

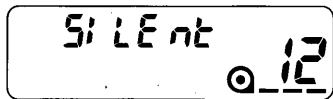

Press the manual-rewind button while the film is rewinding. Press the button again to return to normal winding speed.

- SILEnt appears on the data panel to indicate the silent-rewind mode.



- The mode will remain selected for rewinding the next time.
- Rewinding in this mode takes longer than normal rewinding.

BASIC OPERATION

FULL-AUTO OPERATION

www.butkus.us

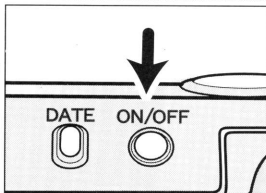
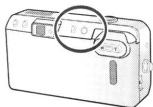

1. Press the main switch to turn the camera on.

- Auto Power Off: To conserve power, the camera automatically turns off if it is not operated for more than 8 minutes.



- Do not obstruct or hold the lens barrel.

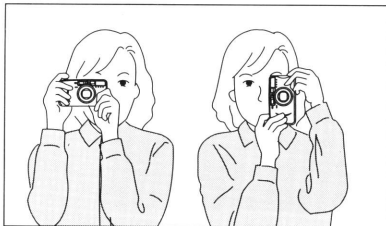

2. Hold the camera steady, making sure your fingers do not cover the flash, lens, or AF windows.

- As shown, for vertically framed pictures, turn the camera so the flash is on top.

Continued on next page.

FULL-AUTO OPERATION

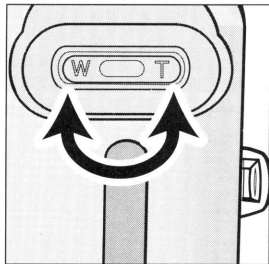
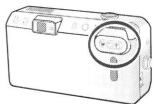

3. Look through the viewfinder and push the zoom lever (T) to zoom in or (W) to zoom out.



T(elephoto) : zoom in



W(ide angle) : zoom out



4. Place the focus frame on the subject and press the shutter-release button partway down.



Ready Lamp

The ready lamp will light to indicate the status of the camera.



On: Focus locked

Off: Flash charging

Blinks quickly: Subject is too close

Blinks slowly: Camera shake warning

FULL-AUTO OPERATION

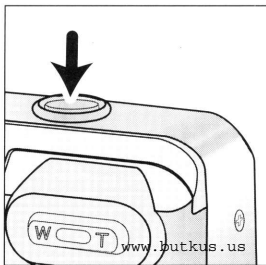
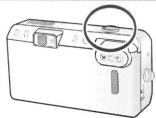

5. When the green ready lamp glows, press the shutter-release button all the way down to take the picture.

- Press the shutter-release button with slow, steady pressure.
- The film automatically advances to the next frame.
- After use, press the main switch to turn the camera off.



- The flash will fire automatically in low-light (p. 39).



Subjects outside the focus frame may not be in focus. Use focus lock to ensure accurate focusing.



1. Place the focus frame on your subject.

FOCUS LOCK



2. Press and hold the shutter-release button partway down until the green ready lamp glows indicating focus lock.



3. Without lifting your finger, recompose the picture and press the shutter-release button all the way down to take the picture.

- The focus lock is canceled when your finger release the shutter button.



FOR CLOSE SUBJECTS

www.butkus.us

When taking a picture with the subject closer than 1.5m (4.9ft.), the viewfinder image and the actual film image will be different. The difference increases as the subject becomes closer, or especially when using the telephoto setting. At the closest range at the telephoto settings, the top of the actual film image is located below the close framing guide.

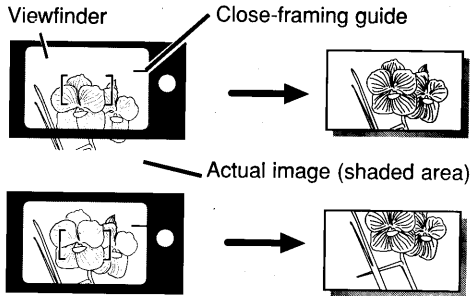

Continued on next page.

FOR CLOSE SUBJECTS

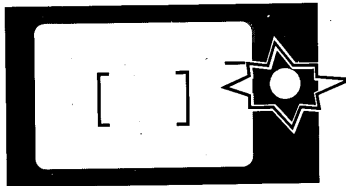

- If the green ready lamp blinks rapidly and the shutter locks, the subject is too close. Be sure your camera-to-subject distance is at least 60cm (2.0 ft.) in the wide-angle setting or 55 cm (1.8 ft.) in the telephoto setting.
- When taking pictures at extremely close distances, the green ready lamp may blink slowly, but the focus may not be accurate.

CLOSE FRAMING GUIDE

If the subject is closer than 1.5m(4.9ft.), take the following steps:



- 1. Place the focus frame on the subject and press the shutter-release button partway down.**



- 2. While pressing the shutter-release button partway down, aim the camera upward to recompose the subject under the close-framing guide and take the picture.**

SPECIAL FOCUSING SITUATIONS

Some scenes or subjects are difficult for the autofocus system to lock on to. When the focus will not lock, focus lock (p. 29) on another object the same distance from you as the main subject, recompose, then take the picture.

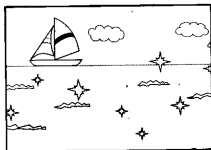

The autofocus may not lock on the following;

- Bright light sources such as the sun or neon lights.
- Highly reflective surfaces such as water or mirrors.
- Flames or fireworks.
- Dark objects and surfaces with low reflectances.
- Objects behind glass, bars, or other such partitions.

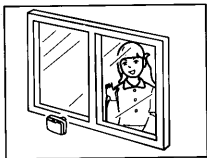

www.butkus.us

ADVANCED OPERATION

SELECTING FLASH-MODE

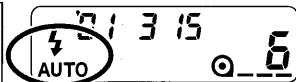
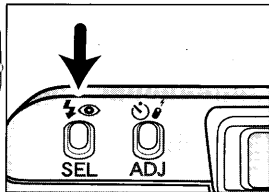
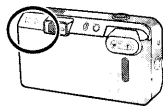

Press the flash-mode button until the desired indicator appears on the data panel.

The following mode can be selected:

 AUTO Autoflash (p. 39)



 AUTO Autoflash with red-eye reduction (p. 40)



 Fill flash (p. 42)



 **Flash cancel (p. 43)**



 **AUTO**  **Auto-depth (p. 44)**



   **Night portrait (p. 46)**



  **Landscape/Night View (p. 47)**



- The autoflash and the autoflash with red-eye reduction will remain selected after you turn the camera off.
- When you turn the camera off, the fill flash / the flash cancel / the auto-depth / the night portrait / the landscape/the night view will be reset to the autoflash or the autoflash with red-eye reduction, whichever was used last.

FLASH RANGE

The range of the built-in flash depends on the film speed and focal length you are using. To ensure proper exposure, make sure your subject is positioned within the flash range.

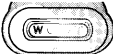
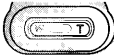
Focal length Film speed	37.5mm  W(ide-angle)	115mm  T(elephoto)
ISO100	0.6- 5.1m 2.0- 16.7ft.	0.55- 2.1m 1.8- 6.9ft.
ISO400	0.6- 10.2m 2.0- 33.5ft.	0.55- 4.3m 1.8- 14.1ft.

These distances are recommended with color negative film.

AUTO AUTOFLASH

The flash will fire automatically in low-light.

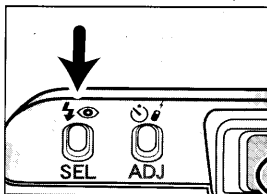
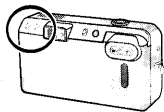

Press the flash-mode button until  appears on the data panel, then take the picture.

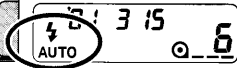

- The flash will not fire in back-lit situations. Use of the fill flash is recommended.
- When the green ready lamp is off, the flash is charging. Wait until it glows, then take the picture.



AUTOFLASH WITH RED-EYE REDUCTION

Use the reduction mode to reduce the red-eye effect when photographing people or animals in low-light situations. The red-eye reduction lamp will blink three times before the main flash will fire.

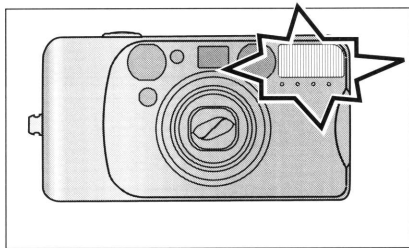
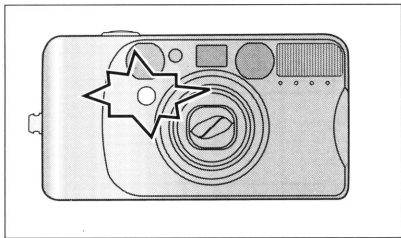

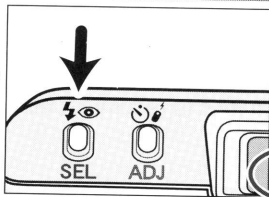
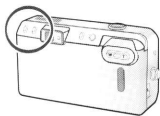

Press the flash-mode button until  appears on the data panel, then take the picture.

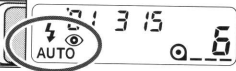

- Warn your subject not to move while the lamp is blinking just before the picture is taken.

⚡ FILL FLASH



The flash will fire when the shutter is released regardless of lighting. Use the fill flash to reduce harsh shadows on your subject's face. Also the use in back-lit situations is recommended.

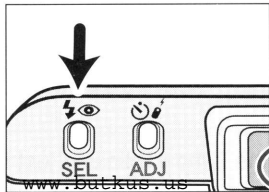
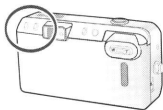

Press the flash-mode button until ⚡ appears on the data panel, then take the picture.

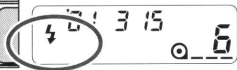





FLASH CANCEL

www.butkus.us

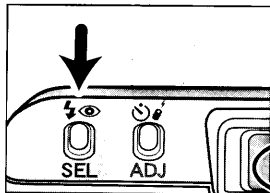
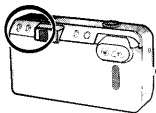
The flash will not fire in this mode. Use the flash cancel when you want to photograph subjects that are beyond the flash range or to capture the ambiance of the existing light.



Press the flash-mode button until  **appears on the data panel, then take the picture.**

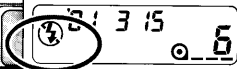

- Shutter speed may be slow and the use of a tripod is recommended.

AUTO AA **AUTO-DEPTH**



The auto-depth is used for taking pictures with both foreground subjects and background subjects in sharp focus. Use this mode when taking portraits where the surrounding landscape is also important.

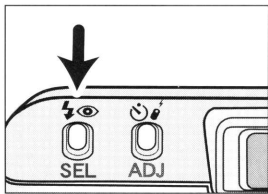
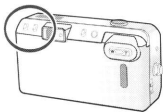

Press the flash-mode button until  AUTO AA appears on the data panel, then take the picture.

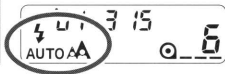





- The flash will fire automatically in low-light.
- If the autoflash with red-eye reduction was chosen previously, the auto-depth mode will also use the red-eye reduction.
- Sharpness of the background depends on brightness and focal length. The brighter the light and the shorter the focal length, the sharper the background. For optimum results, use wide-angle to normal focal lengths. The effect may not be apparent at the telephoto setting.

NIGHT PORTRAIT



In the night portrait mode, the camera balances the flash and existing light exposures so you can take beautiful pictures of people at sunset or at night.

Press the flash-mode button until    appears on the data panel, then take the picture.

- The fill flash with red-eye reduction will be set.



- Shutter speed will be slow. Use of a tripod is recommended and warn your subjects not to move.



▲ LANDSCAPE/NIGHT VIEW www.butkus.us



The flash will not fire in this mode and the focus is set to infinity. It can be used to photograph landscapes, night scenery and other distant subjects.

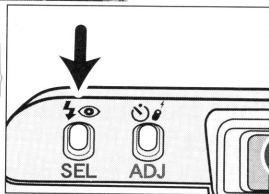
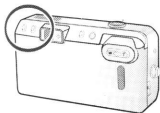

Press the flash-mode button until  ▲ appears on the data panel, then take the picture.



- Shutter speed will be slow. Use of the tripod is recommended.
- Use this mode especially when photographing landscapes through windows.

SELF-TIMER

The self-timer delays release of the shutter for approximately 10 seconds after the shutter-release button is pressed.

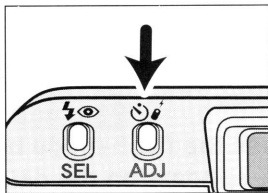
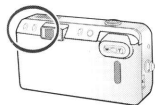

- 1. Place the camera on a tripod, then press the drive-mode button until the self-timer symbol  appears on the data panel.**



- 2. Place the focus frame on your subject.**

- Use focus lock for off-center subjects (p 29).

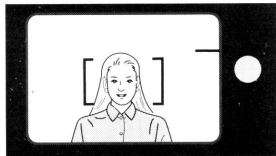

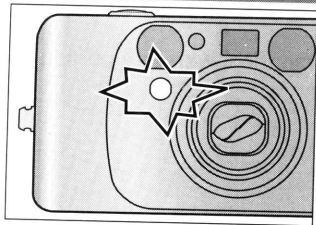

3. Press the shutter-release button all the way down; the self-timer delays release for 10 seconds.

-  will blink on the data panel. The self-timer lamp on the front of the camera will blink slowly during the countdown, then rapidly just before the shutter is released.

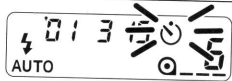

- The autofocus and exposure is locked when the shutter-release button is pressed. Do not stand in front of the camera when using the shutter-release button.



- To cancel the self-timer, press the self-timer button or turn the camera off.
- The self-timer is automatically canceled after the shutter releases.

FOR OWNERS OF THE QUARTZ-DATE MODEL

IMPRINTING THE DATE OR TIME

This feature enables you to record the date or time onto the lower-right portion of the picture.

Buttons for date function

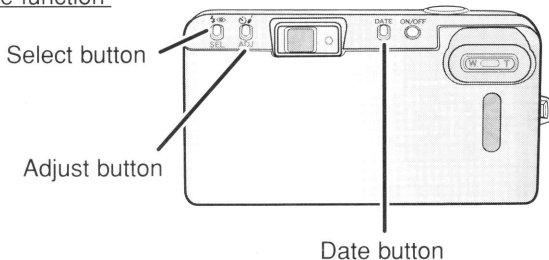

-  Since the date is recorded when the film is advanced to the next frame, sometimes the last frame of the roll will not have a data print.

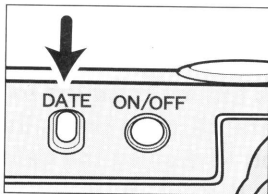
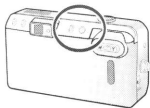

Turn the camera on, then press the date button to choose the data imprinting format.



The display will change as follows :

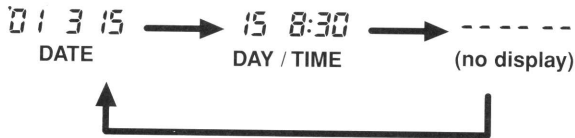

- When the date-time display is blinking or -- -- -- is displayed on the data panel, date/time information will not be imprinted. The date/time information needs to be reset (p.52).

FOR OWNERS OF THE QUARTZ-DATE MODEL

SETTING THE DATE OR TIME

This camera has a quartz clock and automatic calendar through the year 2029.

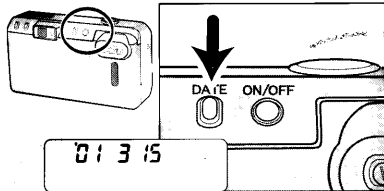

1. Press the main switch to turn the camera off, then press the date button to display the date.

2. Press the select button until the item you want to adjust blinks.

• The next item will blink each time the select button is pressed.

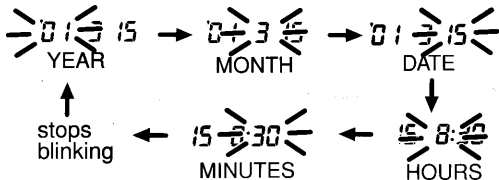
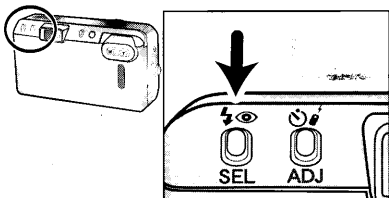

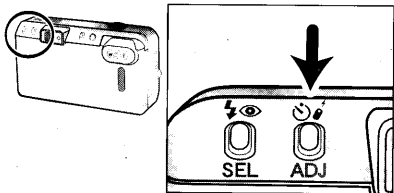

3. Press the adjust button to change the blinking item.

- Data continues changing as long as the button is held down.

4. Repeat steps 2 and 3 until all items on the date and time display are correct.

5. Press the select button until all items stop blinking to set the updated information.

- The set date appears on the data panel and disappears after 5 seconds.

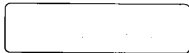
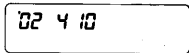

- The date and time must be reset each time the batteries are replaced.

FOR OWNERS OF THE QUARTZ-DATE MODEL

CHANGING THE FORMAT

The order of year/month/day can be changed.

1. Press the main switch to turn the camera off.

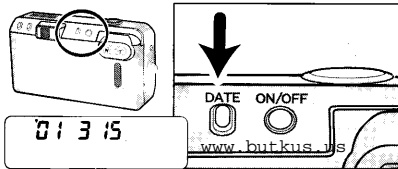

2. Press the date button to display the date.

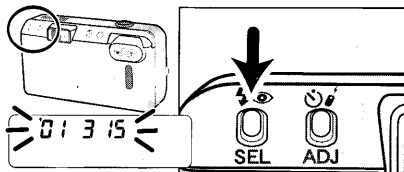

3. Press and hold the select button until all items on the date display blink.

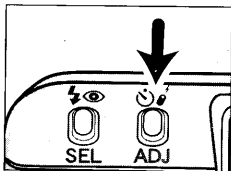
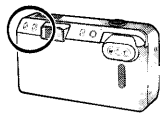

4. Press the adjust button to change the display format.

The format sequences as follows:

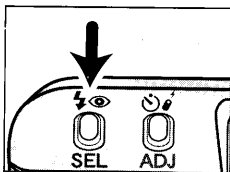
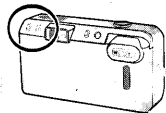
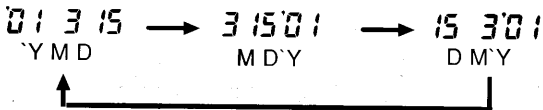

5. Press the select button until all items stop blinking to set the updated information.

- The set date appears on the data panel and disappears after 5 seconds.

ATTACHING THE CAMERA STRAP

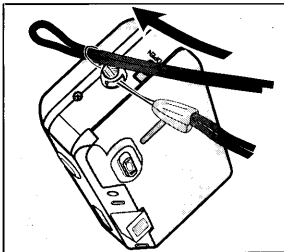
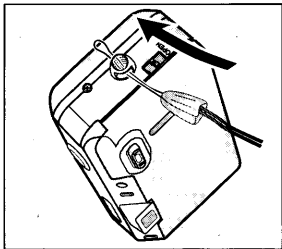

Attach the strap as shown.



BUTTON KEY

- The button key is included on the strap. Use the key to push the manual-rewind button (p.22).

APPENDIX

OPERATING TEMPERATURE AND CONDITIONS

- This camera is designed for use from -10 to 40 °C (14 to 104 °F).
- Never leave your camera where it may be subjected to extreme temperatures such as in the glove compartment of a car.
- At colder temperatures, the data panel response time will be slow. At higher temperatures, the display will temporarily darken, but will be restored when the temperature normalizes.
- Never subject the camera to extreme humidity.
- To prevent condensation from forming, place the camera in a sealed plastic bag when bringing it from a cold environment into a warm environment. Allow it to come to room temperature before removing it from the bag.

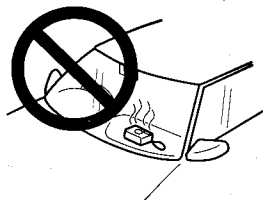

- When photographing in cold weather, it is recommend that you keep the camera and spare batteries inside your coat to keep them warm when you are not shooting. Cold batteries will regain some of their charge when they warm up.
- This camera is not waterproof, dustproof, or sand-proof. If you use this camera near water or the beach, water, dust, or sand damage may occur. Protect it at all times from moisture or splashes, especially saltwater spray, and be extremely careful to keep sand from both the interior and exterior of the camera and its accessories.

CLEANING

- Keep the AF window clean or the focus may not be accurate.
- If the camera body is dirty, gently wipe it clean with a soft, clean, dry cloth.
- To clean the lens surface, first brush away any dust or sand then, if necessary, moisten a lens tissue with lens cleaning fluid and gently wipe the lens in a circular motion, starting from the center.

CARE AND STORAGE

- Never place lens fluid directly on the lens.
- Never touch the lens surface with your fingers.
- Never use alcohol or solvents to clean the camera.

STORAGE

When storing the camera for extended periods, please follow these guidelines:

- Store the camera in a cool, dry, well-ventilated area away from dust and chemicals. For very long periods, place the camera in an airtight container with a silica gel drying agent.
- Before using after prolonged storage, always check the camera's operation to make sure it is functioning properly.

BEFORE IMPORTANT EVENTS

- Check camera operation carefully or take test photographs.
- Minolta is not responsible for any loss which may occur due to an equipment malfunction.

QUESTIONS AND SERVICE

- If you have questions about your camera, contact your local camera dealer or write to the Minolta distributor in your area.
- Before shipping your camera for repair, please contact an authorized Minolta Service Facility for details.

CAMERA ERROR

If all the indicators on the data panel blink, or the data panel is blank and the camera will not function with a fresh battery, remove and reinsert the battery. If normal operation does not resume, or the camera malfunctions repeatedly, contact an authorized Minolta Service Facility.

TECHNICAL SPECIFICATIONS

- Camera Type:** 35mm lens-shutter camera
- Lens:** 37.5-115mm f/5.4 - 10.9 lens
6 element/6 group construction
- Focusing Range:** (W): 0.6m - ∞ (2.0 - ∞)
(T): 0.55m - ∞ (1.8 - ∞)
- Film Speed:** Settings Automatic for DX-coded film.
Non-DX coded film set to ISO100.
Range ISO 25 to 3200
- Metering Range**
(ISO 100): Wide: Ev 3 - 16
Tele: Ev 3.7 - 16
- Shutter Speed:** 10 - 1/390 sec.
- Flash Range**
(ISO 100): Wide: 0.6 - 5.1m (2.0 - 15.2 ft.)
Tele: 0.55 - 2.1m (2.8 - 6.6 ft.)

- Battery:** One 3-volt CR123A lithium battery
Battery-condition indication: 3-stage indication
Battery performance: approx. 12 rolls based on Minolta's standard test method using 24 exposure rolls with flash for 50% of the exposures.
- Viewfinder:** Magnification: 0.4X - 1.09X
Field of View : 86% (subject at 3m)
Eye-relief: 15.9mm from the viewfinder frame
- Dimensions:** 112 x 60 x 39mm
5.1x2.7x1.5 in
- Weight:** 205g (7.2oz.) without battery

Specifications are based on the latest information available at the time of printing and are subject to change without notice.